

1. Main

Exploded View

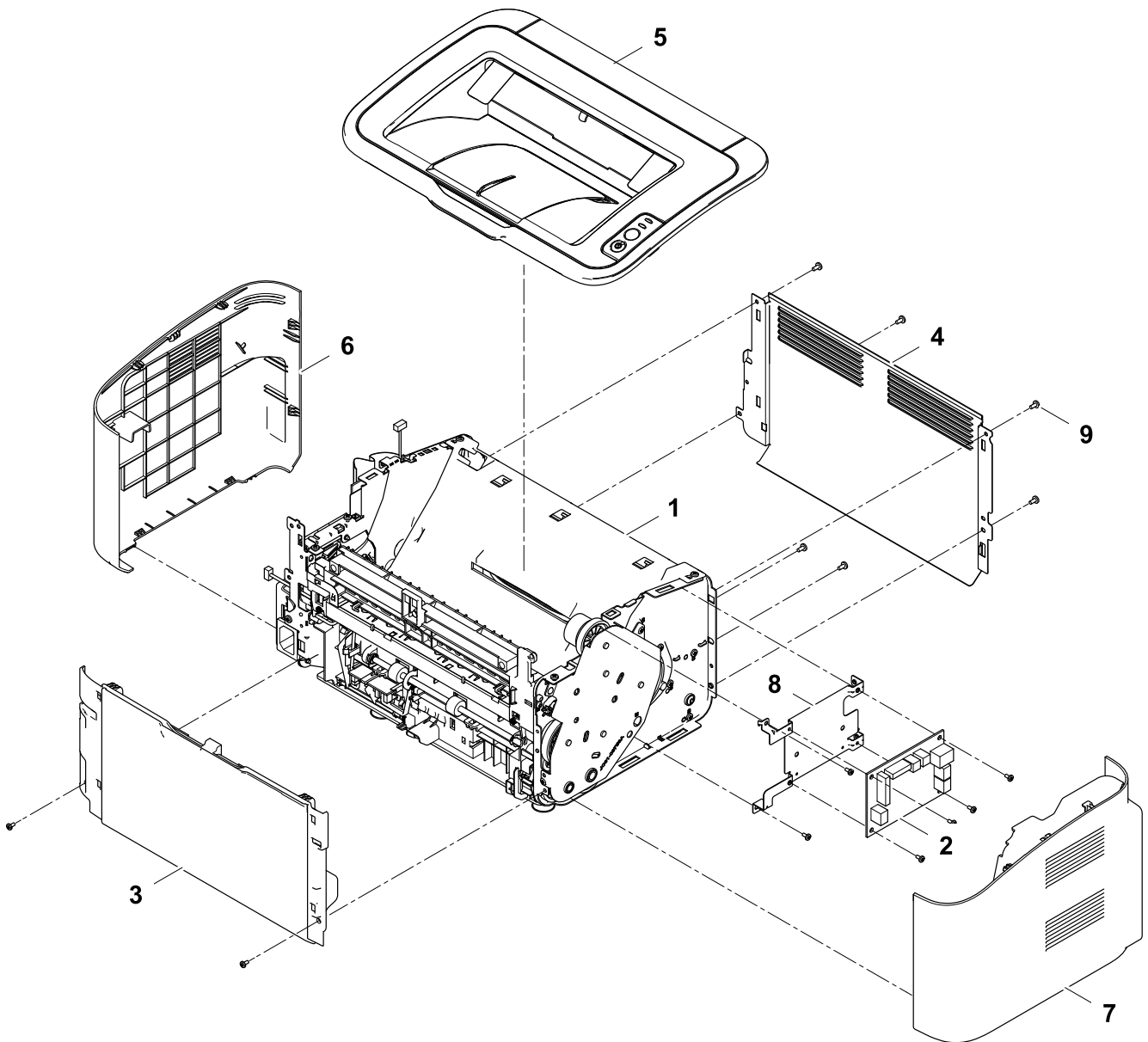

Parts List

No.	Parent	Lvl.	Loc.	Material Code	Description & Specification	SNA	Qty.
1	ML-1670/SEE	1		JC93-00335E	FRAME; ML-1670,SEC,SEE	SNA	1
2	ML-1670/SEE	1		JC92-02375E	PBA-MAIN; ML-1670,SEC,MAIN,EUR,64.25mmX90	SA	1
3	JC95-01448A	2		JC95-01214C	COVER-FRONT; ML-1670,SEC,CREMA GRAY	SA	1
4	JC95-01448A	2	L9437	JC61-03787A	BRACKET-REAR; ML-1660,SECC,0.6	SNA	1
5	ML-1670/SEE	1		JC95-01447A	COVER-TOP; ML-1670,SEC,CREMA GRAY	SA	1

Exploded Views and Parts List

No.	Parent	Lvl.	Loc.	Material Code	Description & Specification	SNA	Qty.
6	JC95-01448A	2		JC95-01212B	COVER-LEFT; ML-1670,SEC,CREMA GRAY	SA	1
7	JC95-01448A	2		JC95-01213B	COVER-RIGHT; ML-1670,SEC,CREMA GRAY	SA	1
8	JC98-01340C	2		JC61-04164A	BRACKET-MAIN_BOARD; ML-1860,SECC,0.6,119.	SNA	1
9	JC98-01340C	2	F9840	6003-000269	SCREW-TAPTYPE; BH,+,-,S,M3,L6,ZPC(WHT),SW	SA	12

2. Frame-Main

Exploded View

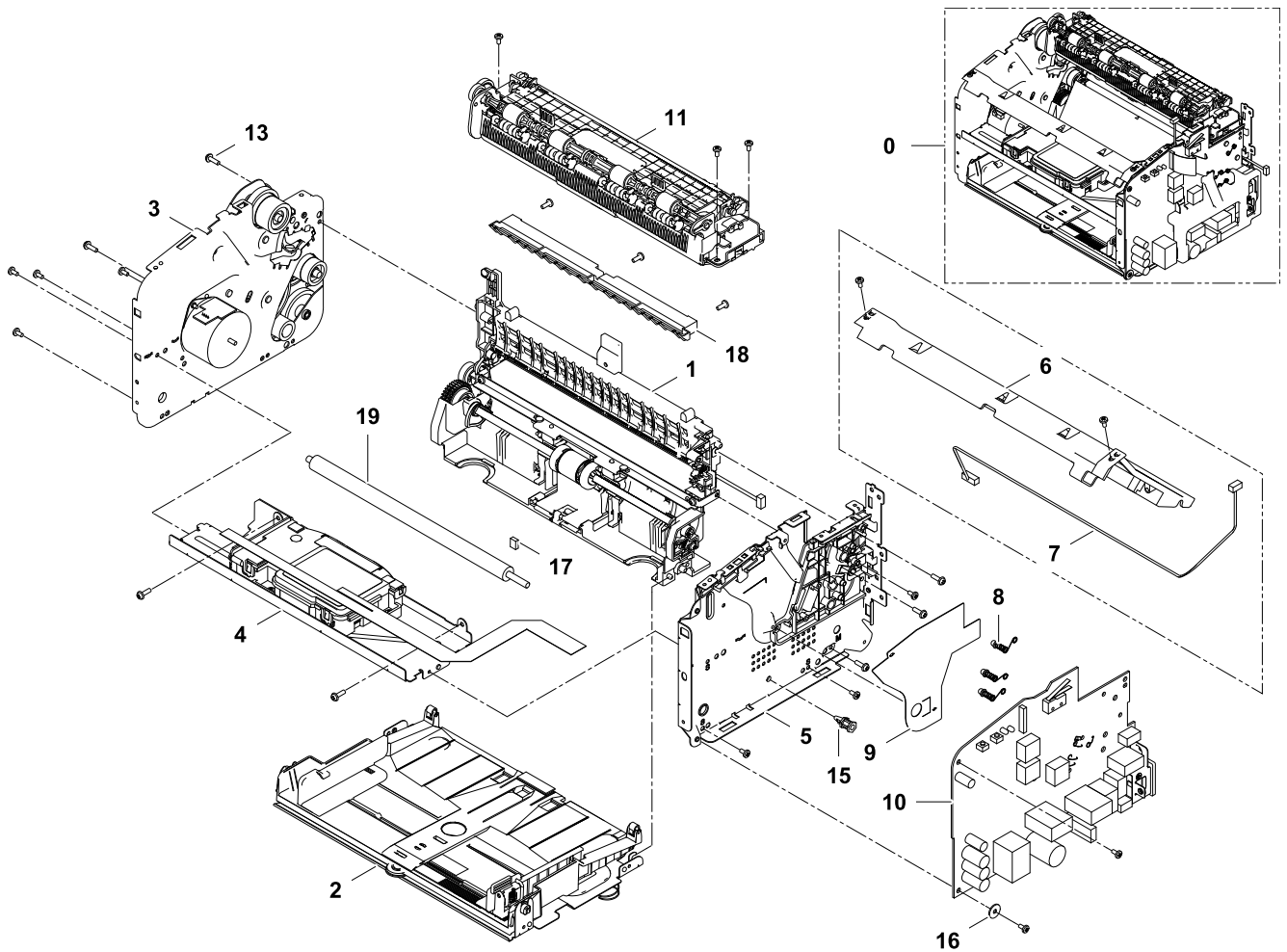

Parts List

No.	Parent	Lvl.	Loc.	Material Code	Description & Specification	SNA	Qty.
0	ML-1670/SEE	1		JC93-00335E	FRAME; ML-1670,SEC,SEE	SNA	1
1	JC93-00335E	2	L9550	JC93-00214A	FRAME-PAPER PATH; ML-1660,SEC	SNA	1
2	JC93-00335E	2		JC93-00221D	FRAME MAIN-BOTTOM; ML-1670,SEC	SNA	1
3	JC93-00335E	2	L9554	JC93-00218A	FRAME MAIN-LEFT; ML-1660,SEC,SECC,1.0,NTR	SNA	1
4	JC93-00335E	2		JC93-00220B	FRAME MAIN-MIDDLE; ML-1860,SEC,SECC,0.8,N	SNA	1
5	JC93-00335E	2	L9555	JC93-00219A	FRAME MAIN-RIGHT; ML-1660,SEC,SECC,0.8,NT	SNA	1
6	JC93-00335E	2	L9453	JC63-02608A	COVER-LSU; ML-1660,PP,BLACK	SNA	1
7	JC93-00335E	2	L9390	JC39-01354A	HARNESS-MOTOR; ML-1660,4,450mm,Black/Gray	SA	1

Exploded Views and Parts List

No.	Parent	Lvl.	Loc.	Material Code	Description & Specification	SNA	Qty.
8	JC93-00335E	2	L9553	JC93-00217A	FRAME-TERMINAL; ML-1660,SEC,WORLDWIDE,SUS	SA	3
9	JC93-00335E	2	L9473	JC63-02758A	SHEET-INSULATOR; ML-1660,PC,0.254,100.5,5	SNA	1
10	JC93-00335E	2		JC44-00189A	SMPS/HVPS-V2; ML-1660,BLUEBIRD-V2,FLYBACK	SA	1
11	JC93-00335E	2		JC91-00991B	FUSER; ML-1660,SEC,SEE,220V	SA	1
13	JC93-00335E	2	F9909	6003-000196	SCREW-TAPTYPE; PWH,+,B,M3,L10,NI PLT,SWRC	SA	7
15	JC93-00335E	2		6103-000117	SUPPORTER; DACN-6N,L10,NTR,NYLON66	SNA	1
16	JC93-00335E	2		6031-002061	WASHER-PLAIN; SPCC,ID3.5,OD12,T1.0,+3 ZN-	SNA	1
17	JC93-00335E	2	G1215	JC72-01444A	SPONGE-GUIDE CHANGE DUP; ML-2851ND/XAA,PO	SNA	1
18	JC93-00335E	2	L9426	JC61-03775A	GUIDE-INPUT; ML-1660,PET+GF30%,218,BLACK,	SNA	1
19	JC93-00335E	2	L9509	JC66-02709A	ROLLER-TRANSFER; ML-1660,NBR+ECO+SUM22L+N	SA	1

2.1. Fuser

Exploded View

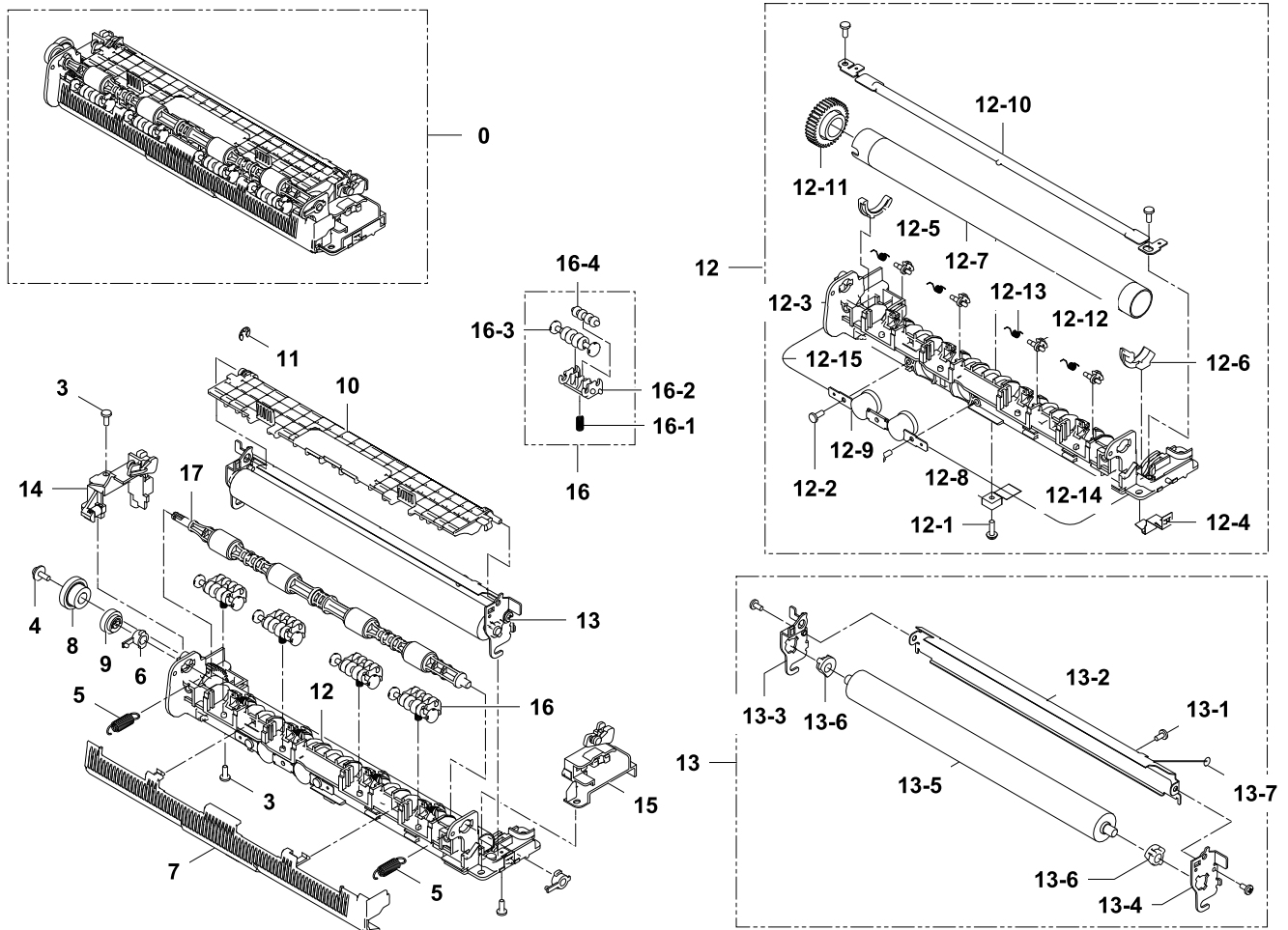

Parts List

No.	Parent	Lvl.	Loc.	Material Code	Description & Specification	SNA	Qty.
0	JC93-00335E	2		JC91-00991B	FUSER; ML-1660,SEC,SEE,220V	SA	1
3	JC96-05875A	3	F9835	6003-000282	SCREW-TAPTYPE; BH,+,-,B,M3,L8,ZPC(BLK),SW	SNA	4
4	JC91-00991B	3	F9900	6006-001078	SCREW-TAPTYPE; PH,+ ,WSP,B,M3,L10,ZPC(WHT)	SA	1
5	JC91-00991B	3	L9380	6107-002664	SPRING-ES; SWP B,PI0.85,L24.4,OD7.0,14.25	SNA	2
6	JC91-00991B	3	L9432	JC61-03782A	BUSH-SHAFT_EXIT; ML-1660,POM,5,9.1,WHITE,	SNA	2
7	JC91-00991B	3	L9461	JC63-02616A	COVER-EXIT; ML-1660,PC,1.7T	SNA	1
8	JC91-00991B	3	L9488	JC66-02583A	GEAR-EXIT DRV; ML-1660,POM,0.8/0.8,z24,z1	SNA	1
9	JC91-00991B	3	L9494	JC66-02589A	GEAR-EXIT; ML-1660,POM,0.8,z17,NATURAL,15	SNA	1

Exploded Views and Parts List

No.	Parent	Lvl.	Loc.	Material Code	Description & Specification	SNA	Qty.
10	JC91-00991B	3	L9458	JC63-02613A	COVER-FUSER_DUMMY; ML-1660,PET+GF30,1.7T	SNA	1
11	JC93-00214A	3	F8266	6044-000125	RING-E; ID4,OD9,T0.6,STSC	SA	2
12	JC91-00991B	3		JC91-00983B	FUSER-UPPER; ML-1660,SEC,SEE,220V	SNA	1
12-1	JC91-00983B	4	F9909	6003-000196	SCREW-TAPTYPE; PWH,+ ,B,M3,L10,NI PLT,SWRC	SA	1
12-3	JC91-00983B	4	L9457	JC63-02612A	COVER; ML-1660,PET+GF30,BLACK	SNA	1
12-4	JC91-00983B	4	L9462	JC63-02617A	GROUND-HR; ML-1660,SUS,0.2,19.1	SNA	1
12-5	JC91-00983B	4	L9409	JC61-03754A	BUSH-HR_L; ML-1660,PPS,25.1,17.4,BLACK,CO	SA	1
12-6	JC91-00983B	4	L9410	JC61-03755A	BUSH-HR_R; ML-1660,PPS,17.6,BLACK,CONDUCT	SA	1
12-7	JC91-00983B	4	L9510	JC66-02715A	ROLLER-HEAT; ML-1660,AL5052,18.1,247.5	SA	1
12-8	JC91-00983B	4	L9361	1404-001541	THERMISTOR-NTC ASSY; 7Kohm,3370K,0.3mW/C	SA	1
12-9	JC91-00983B	4	M0316	4712-001084	THERMOSTAT; 125/250VAC,15/7.5A,195+-5C,0C	SNA	1
12-10	JC91-00983B	4		4713-001520	LAMP-HALOGEN; 230V,600W,287	SA	1
12-11	JC91-00983B	4	F4094	JC66-00564A	GEAR-FUSER Z37; ML-1710,PPS OFL4036,0.8,3	SA	1
12-12	JC91-00983B	4	L9444	JC61-03970A	GUIDE-CLAW; ML-1660,PTFE,WHITE,CLAW	SNA	4
12-13	JC91-00983B	4	L9382	6107-002674	SPRING-TS; SUS304,PI0.35,L6.475,ID3.2,OD3	SNA	4
12-14	JC91-00983B	4	L9391	JC39-01355A	HARNESS-FUSER; ML-1660,3,300mm,WHT,#18,35	SNA	1
12-15	JC91-00983B	4	L9392	JC39-01356A	HARNESS-FUSER_JOINT; ML-1660,1,125mm,WHT,	SNA	1
13	JC91-00991B	3	L9537	JC91-00984A	FUSER-LOWER; ML-1660,SEC,PR 20PI	SNA	1
13-1	JC91-00984A	4	F9840	6003-000269	SCREW-TAPTYPE; BH,+ ,-,S,M3,L6,ZPC(WHT),SW	SA	3
13-2	JC91-00984A	4	L9430	JC61-03779A	FRAME-FUSER; ML-1660,SECC,0.6T	SNA	1
13-3	JC91-00984A	4	L9433	JC61-03783A	BRACKET-PR_L; ML-1660,SECC,1.2T,47.7	SNA	1
13-4	JC91-00984A	4	L9434	JC61-03784A	BRACKET-PR_R; ML-1660,SECC,1.2T,46.7	SNA	1
13-5	JC91-00984A	4	L9511	JC66-02716A	ROLLER-PRESSURE; ML-1660,SUM22/23,20,237.	SA	1
13-6	JC91-00984A	4	L9411	JC61-03756A	BUSH-PR; ML-1660,PPS,6.1,10,BLACK,CONDUCT	SA	2
13-7	JC91-00984A	4	H2655	JB39-00017A	CBF HARNESS-EARTH (TX MOTOR); SF-3100,UL	SC	1
14	JC91-00991B	3	L9540	JC91-00987A	FUSER-LEFT; ML-1660,SEC	SNA	1
15	JC91-00991B	3	L9539	JC91-00986A	FUSER-RIGHT; ML-1660,SEC	SNA	1

No.	Parent	Lvl.	Loc.	Material Code	Description & Specification	SNA	Qty.
16	JC91-00991B	3	L9625	JC91-00989A	FUSER-GUIDE HOLDER L; ML-1660,SEC,54	SNA	4
16-1	JC91-00989A	4	L9381	6107-002665	SPRING-CS; SUS304,PI0.45,L10.6,ID3.5,Free	SNA	4
16-2	JC91-00989A	4	L9431	JC61-03781A	HOLDER-EXIT_F_DOWN; ML-1660,PC,BLACK	SNA	4
16-3	JC91-00989A	4	L9513	JC66-02742A	ROLLER-EXIT_MAIN; ML-1660,POM,9.2,BLACK	SA	4
16-4	JC91-00989A	4	R0128	JC66-00934A	ROLLER-M_EXIT FR; ML-1610,TEFLON-NTR,6.5,	SNA	4
17	JC91-00991B	3	L9538	JC91-00985A	FUSER-EXIT ROLLER; ML-1660,SEC,13.9PI	SNA	1

2.2. Frame-Paper Path

Exploded View

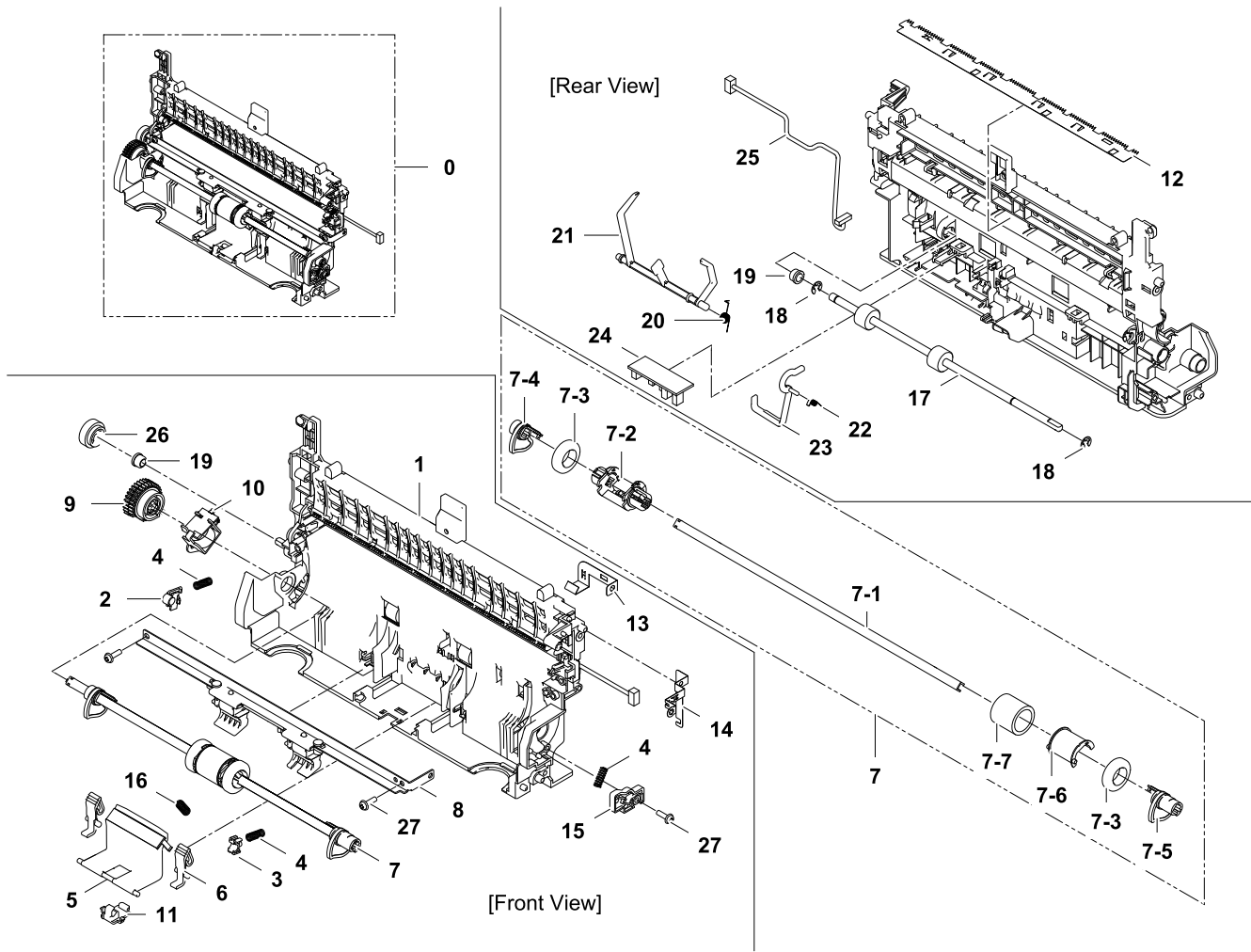

Parts List

No.	Parent	Lvl.	Loc.	Material Code	Description & Specification	SNA	Qty.
0	JC93-00335E	2	L9550	JC93-00214A	FRAME-PAPER PATH; ML-1660,SEC	SNA	1
1	JC93-00214A	3	L9429	JC61-03778A	GUIDE-PAPER PATH; ML-1660,ABS,266,158.19,	SA	1
2	JC93-00214A	3	L9428	JC61-03777A	BUSH-TR L; ML-1660,POM	SA	1
3	JC93-00214A	3	L9427	JC61-03776A	BUSH-TR R; ML-1660,POM	SA	1
4	JC93-00214A	3	G1432	JC61-70940A	SPRING ETC-TR(12); ML-5500,0.5,5,13,SUS30	SA	3
5	JC93-00214A	3	L9547	JC93-00211A	FRAME-HOLDER PAD; ML-1660,SEC	SA	1
6	JC93-00214A	3	L9497	JC66-02592A	LEVER-KICKER PU; ML-1660,ABS,2.0,12.0,28.	SA	2
7	JC93-00214A	3	L9548	JC93-00212A	FRAME-PICKUP; ML-1660,SEC	SA	1
7-1	JC93-00212A	4	L9425	JC61-03774A	BRACKET-SHAFT_PICKUP; ML-1660,SEFC,1,6,26	SNA	1

No.	Parent	Lvl.	Loc.	Material Code	Description & Specification	SNA	Qty.
7-2	JC93-00212A	4	L9418	JC61-03764A	HOUSING-PICKUP B; ML-1660,ABS+PC,18.9,46,	SNA	1
7-3	JC93-00212A	4	L9512	JC66-02725A	ROLLER-PICKUP_IDLE; ML-1660,SWCH10A,22.6	SNA	2
7-4	JC93-00212A	4	L9499	JC66-02594A	CAM-PICKUP_L; ML-1660,POM (F20-02),2	SNA	1
7-5	JC93-00212A	4	L9498	JC66-02593A	CAM-PICKUP_R; ML-1660,POM(F20-02),2	SNA	1
7-6	JC93-00212A	4	L9417	JC61-03763A	HOUSING-PICKUP A; ML-1660,ABS+PC,20.2,AMB	SNA	1
7-7	JC93-00212A	4	L9533	JC73-00321A	RUBBER-PICK UP; ML-1660,EPDM,20,21,35,GRA	SA	1
8	JC93-00214A	3	L9558	JC93-00223A	FRAME-FEED IDLE; ML-1660,SEC	SNA	1
9	JC93-00214A	3	L9549	JC93-00213A	FRAME-PICKUP GEAR; ML-1660,SEC	SA	1
10	JC93-00214A	3	L9388	JC33-00028C	SOLENOID-MP; ML-1660,DC-24V,120ohm,525mm,	SA	1
11	JC93-00214A	3	L9443	JC61-03969A	HINGE-HOLDER_PAD; ML-1660,POM(F20-02)	SA	1
12	JC93-00214A	3	E9623	JC61-00604A	PLATE-P-SAW; ML-1400,SUS304-CSP,0.15,15.1	SNA	1
13	JC93-00214A	3	L9470	JC63-02625A	GROUND-SAW; ML-1660,SUS,0.2,36.4,18.5	SNA	1
14	JC93-00214A	3	L9471	JC63-02626A	GROUND-THV; ML-1660,SUS,0.2,44.9,29.95	SNA	1
15	JC93-00214A	3	C5143	JC61-01548A	HOLDER-M-CAM; CLP-300,POM (DE8903),18.5,2	SA	1
16	JC93-00214A	3	L9374	6107-002617	SPRING-CS; SUS304,PI0.45,D4.95,L16.5,ID4.	SA	1
17	JC93-00214A	3	L9502	JC66-02598A	ROLLER-FEED; ML-1660,EPDM+SUM,5,214.4,GRA	SA	1
18	JC93-00214A	3	F8266	6044-000125	RING-E; ID4,OD9,T0.6,STSC	SA	2
19	JC93-00214A	3	F0104	JB72-00819A	PMO-BUSH; SCX-1110F,POM,NTR	SA	2
20	JC93-00214A	3	L9379	6107-002634	SPRING-TS; SUS304,PI0.26,ID5.6,OD6.12,LEF	SA	1
21	JC93-00214A	3	L9496	JC66-02591A	ACTUATOR-EMPTY; ML-1660,ABS,Black	SA	1
22	JC93-00214A	3	L9378	6107-002633	SPRING-TS; SUS304,PI0.2,ID2.7,OD3.1,LEFT,	SA	1
23	JC93-00214A	3	L9495	JC66-02590A	ACTUATOR-FEED; ML-1660,PC,Black	SA	1
24	JC93-00214A	3	L9546	JC92-02288A	PBA-FEED SENSOR; ML-1660,SEC,FEED SENSOR,	SA	1
25	JC93-00214A	3	L9389	JC39-01353A	HARNESS-SENSOR; ML-1660,5,175mm,Black/Gra	SNA	1

Exploded Views and Parts List

No.	Parent	Lvl.	Loc.	Material Code	Description & Specification	SNA	Qty.
26	JC93-00214A	3	L9490	JC66-02585A	GEAR-FEED; ML-1660,POM,0.8,z21,NATURAL,SP	SA	1
27	JC93-00214A	3	F9909	6003-000196	SCREW-TAPTYPE; PWH,+,B,M3,L10,NI PLT,SWRC	SA	4

2.3. Frame Main-Left

Exploded View

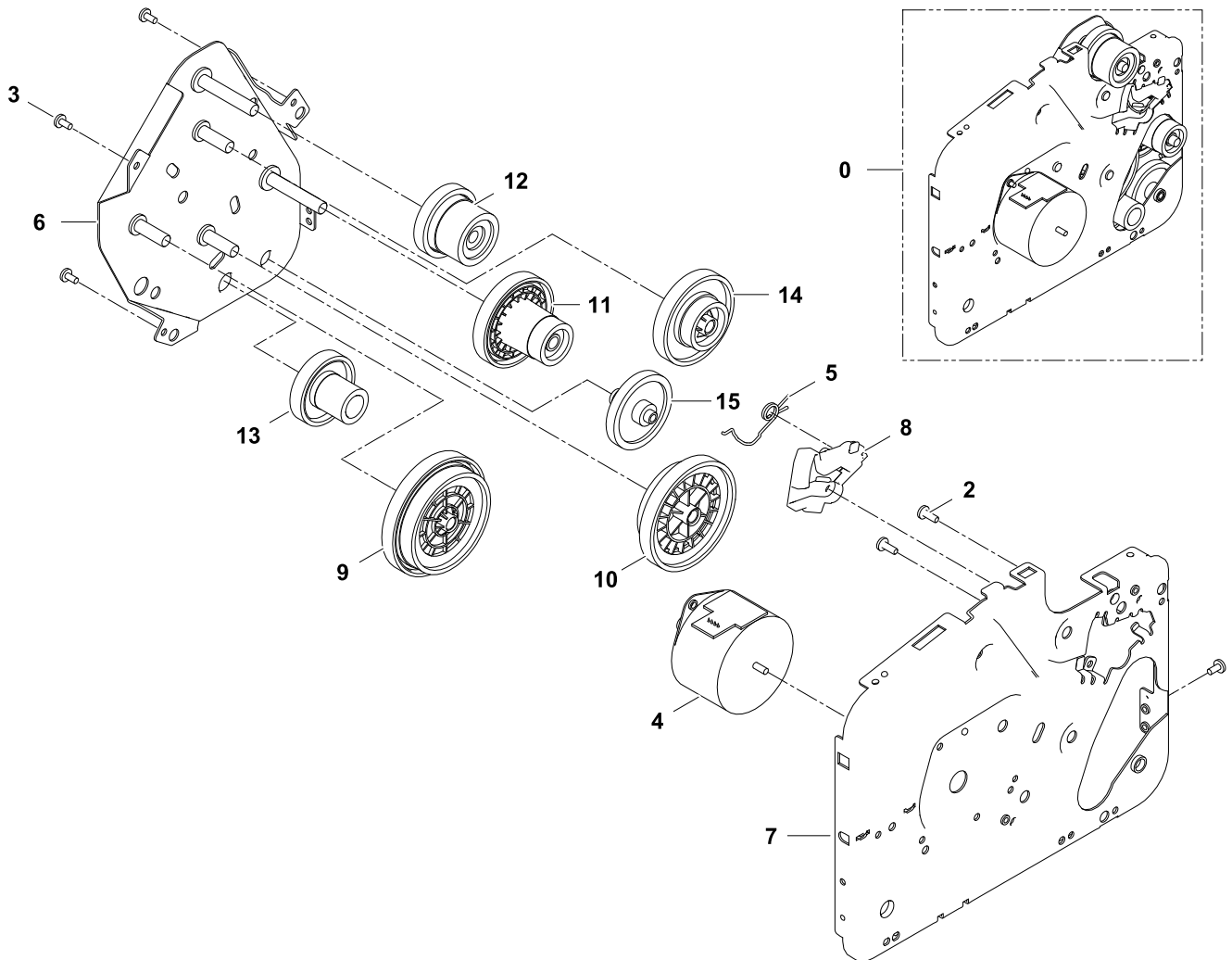

Parts List

No.	Parent	Lvl.	Loc.	Material Code	Description & Specification	SNA	Qty.
0	JC93-00335E	2	L9554	JC93-00218A	FRAME MAIN-LEFT; ML-1660,SEC,SECC,1.0,NTR	SNA	1
2	JC96-05875A	3	F9835	6003-000282	SCREW-TAPTYPE; BH,+,-,B,M3,L8,ZPC(BLK),SW	SNA	4
3	JC93-00220B	3	F9840	6003-000269	SCREW-TAPTYPE; BH,+,-,S,M3,L6,ZPC(WHT),SW	SA	5
4	JC93-00218A	3	L9386	JC31-00134B	MOTOR STEP; ML-1660,1.18A,800PPS,DC 24V	SA	1
5	JC93-00218A	3	L9377	6107-002626	SPRING-TS; SWP B,PI1.1,D7.5,ID6.4,OD8.6,2	SNA	1
6	JC93-00218A	3	L9412	JC61-03758A	BRACKET-GEAR; ML-1660,SECC,1.0T,150.8,129	SNA	1
7	JC93-00218A	3	L9414	JC61-03760A	FRAME-LEFT; ML-1660,SECC,1.0	SNA	1

Exploded Views and Parts List

No.	Parent	Lvl.	Loc.	Material Code	Description & Specification	SNA	Qty.
8	JC93-00218A	3	L9420	JC61-03766A	GUIDE-DEVE RAIL L; ML-1660,PC ABS,BLACK	SNA	1
9	JC93-00218A	3	L9483	JC66-02578A	GEAR-RDCN A; ML-1660,POM,0.4/0.5,z139,z94	SNA	1
10	JC93-00218A	3	L9491	JC66-02586A	GEAR-RDCN OPC; ML-1660,POM,0.5/0.5,z102,z	SNA	1
11	JC93-00218A	3	L9486	JC66-02581A	GEAR-OPC DRV; ML-1660,POM,0.5,0.8,z83,z23	SNA	1
12	JC93-00218A	3	L9487	JC66-02582A	GEAR-FUSER DRV; ML-1660,POM,0.5/0.8,z64,z	SNA	1
13	JC93-00218A	3	L9485	JC66-02580A	GEAR-RDCN FEED; ML-1660,POM,0.5,0.8,z64,z	SNA	1
14	JC93-00218A	3	L9484	JC66-02579A	GEAR-RDCN FUSER; ML-1660,POM,0.4/0.5,z105	SNA	1
15	JC93-00218A	3	L9489	JC66-02584A	GEAR-FEED DRV; ML-1660,POM,0.8,z45,NATURA	SNA	1

2.4. Frame Main-Middle and Right

Exploded View

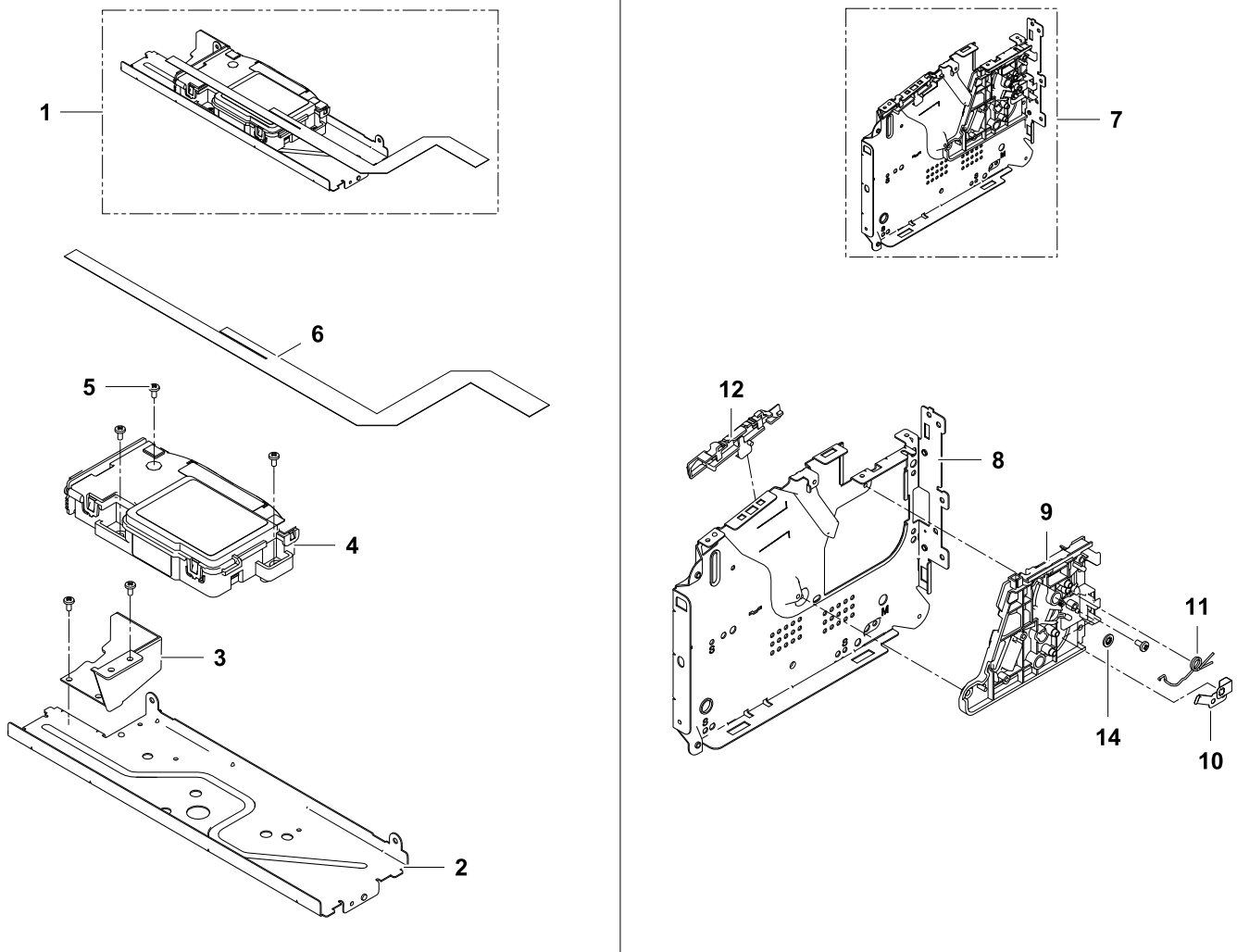

Parts List

No.	Parent	Lvl.	Loc.	Material Code	Description & Specification	SNA	Qty.
1	JC93-00335E	2		JC93-00220B	FRAME MAIN-MIDDLE; ML-1860,SEC,SECC,0.8,N	SNA	1
2	JC93-00220B	3	L9422	JC61-03769A	BRACKET-LSU; ML-1660,SECC,0.8	SNA	1
3	JC93-00220B	3	L9454	JC63-02609A	COVER-MOTOR; ML-1660,ABS,BLACK	SA	1
4	JC93-00220B	3		JC97-03775B	LSU; ML-1860,SEC,Single,A4(Ltr),600,S1,78	SA	1
5	JC93-00220B	3	F9840	6003-000269	SCREW-TAPTYPE; BH,+,-,S,M3,L6,ZPC(WHT),SW	SA	5
6	JC93-00220B	3	L9394	JC39-01358A	FLAT CABLE; ML-1660,16,549mm,AWM20624,1.0	SA	1
7	JC93-00335E	2	L9555	JC93-00219A	FRAME MAIN-RIGHT; ML-1660,SEC,SECC,0.8,NT	SNA	1

Exploded Views and Parts List

No.	Parent	Lvl.	Loc.	Material Code	Description & Specification	SNA	Qty.
8	JC93-00219A	3	L9415	JC61-03761A	FRAME-RIGHT; ML-1660,SECC,0.8	SNA	1
9	JC93-00219A	3	L9421	JC61-03767A	GUIDE-DEVE RAIL R; ML-1660,PC ABS,BLACK	SNA	1
10	JC93-00219A	3	L9452	JC63-02606A	GROUND-OPC; ML-1660,SUS,0.2T	SNA	1
11	JC93-00219A	3	L9376	6107-002625	SPRING-TS; SWP B,PI1.1,D7.5,ID6.4,OD8.6,2	SNA	1
12	JC93-00219A	3	L9419	JC61-03765A	HOLDER-HARNESS; ML-1660,ABS,2,BLACK,V0	SNA	1
14	JC93-00219A	3	F8258	6044-000001	RING-CS; ID3,OD3,T0.25,BLACK,SUS304	SNA	1

2.5. Frame Main-Bottom

Exploded View

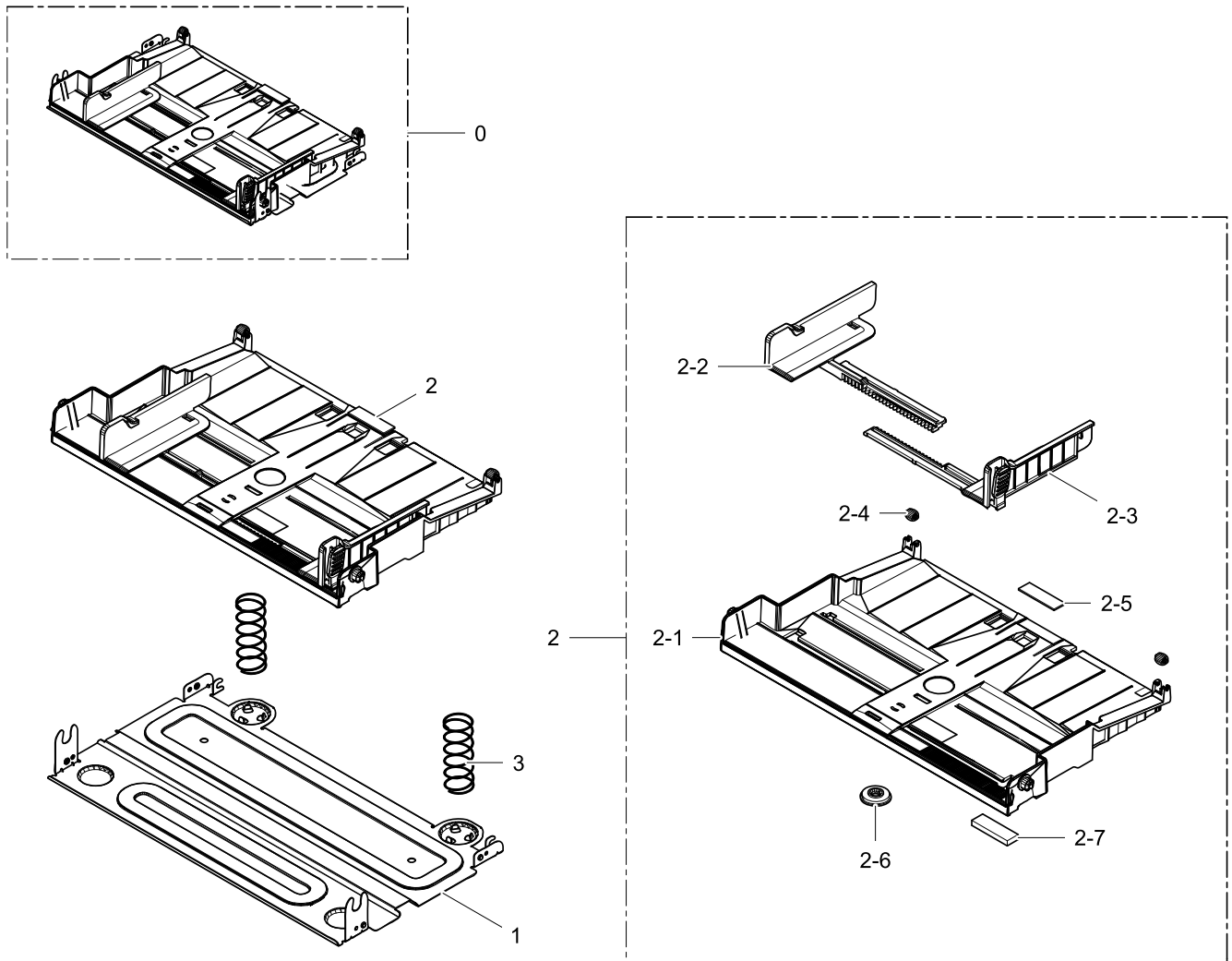

Parts List

No.	Parent	Lvl.	Loc.	Material Code	Description & Specification	SNA	Qty.
0	JC93-00335E	2		JC93-00221D	FRAME MAIN-BOTTOM; ML-1670,SEC	SNA	1
1	JC93-00221D	3	L9416	JC61-03762A	FRAME-BOTTOM; ML-1660,SECC,0.6	SNA	1
2	JC93-00221D	3		JC93-00216D	FRAME-PLATE KNOCK UP; ML-1670,SEC	SA	1
2-1	JC93-00216D	4	L9438	JC61-03788A	PLATE-KNOCKUP; ML-1660,HIPS,2.3,275.5	SNA	1
2-2	JC93-00216D	4		JC70-00580B	ADJUST-CASSETTE_L; ML-1670,HIPS,1.7,120.5	SNA	1
2-3	JC93-00216D	4		JC70-00581B	ADJUST-CASSETTE_R NEW; ML-1660,HIPS,1.7,1	SNA	1
2-4	JC93-00216D	4	L9532	JC72-01585A	PMO-IDLE KNOCK UP MP; ML-1660,TPU,NATURAL	SNA	2

Exploded Views and Parts List

No.	Parent	Lvl.	Loc.	Material Code	Description & Specification	SNA	Qty.
2-5	JC93-00216D	4	E1457	JC74-00011A	MPR-PAD KNOCK UP MP; ML-6060A,CR+CORK,NTR	SA	1
2-6	JC93-00216D	4	C3690	JG66-40003A	GEAR-PINION; SF4000,POM,1,Z16,WHT	SA	1
2-7	JC93-00216D	4	L9531	JC72-01581A	SPONGE-PICKUP; ML-1660,PORON,4,10,32.5,BL	SA	1
3	JC93-00221D	3	L9373	6107-002592	SPRING-CS; SWP B,PI0.8,D19.3,L57,ID18.5,O	SA	2

3. Cover-Top

Exploded View

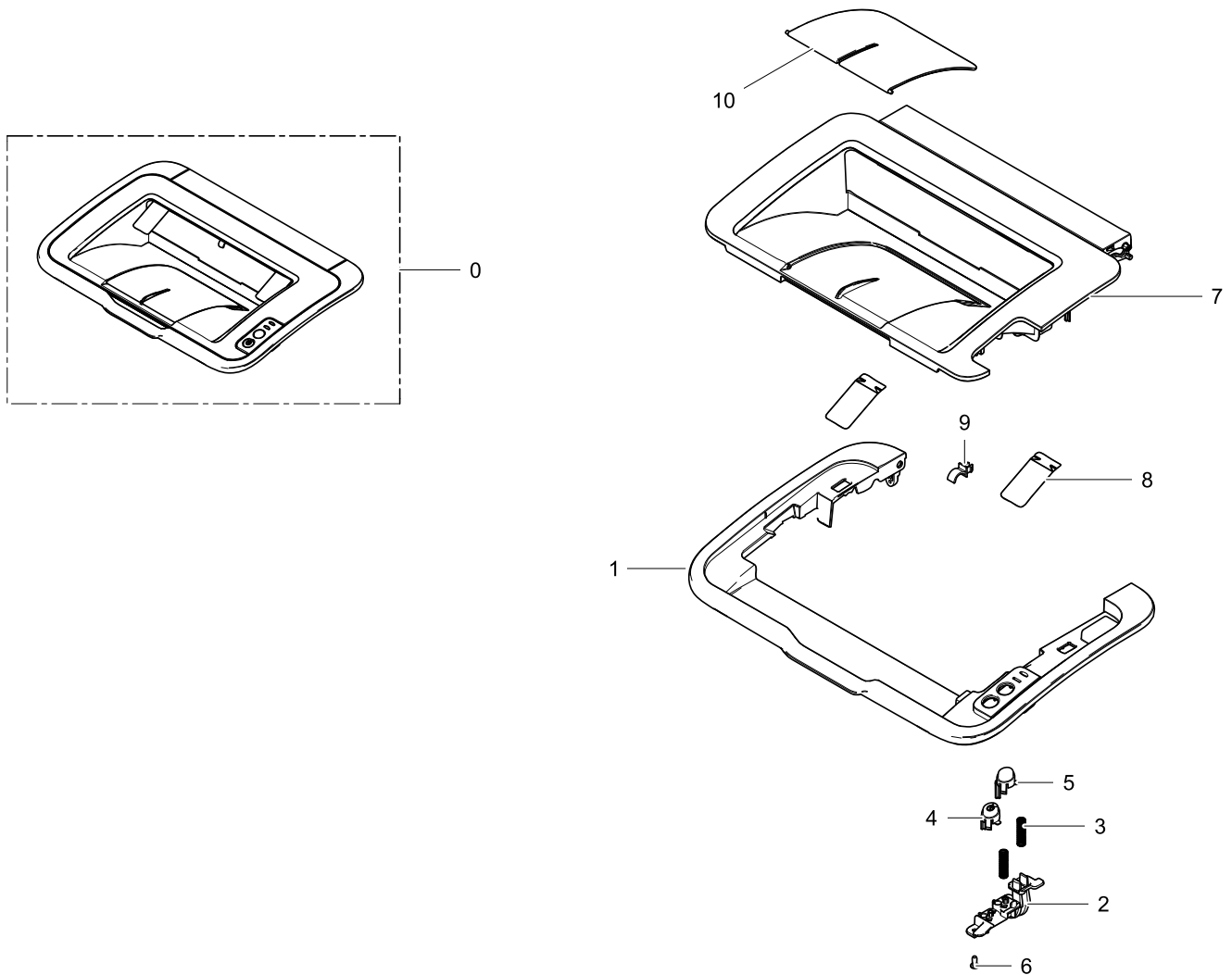

Parts List

No.	Parent	Lvl.	Loc.	Material Code	Description & Specification	SNA	Qty.
0	ML-1670/SEE	1		JC95-01447A	COVER-TOP; ML-1670,SEC,CREMA GRAY	SA	1
1	JC95-01447A	2		JC63-03141A	COVER-TOP; ML-1670,ABS,2,BLACK	SNA	1
2	JC95-01447A	2	L9516	JC67-00449A	LENS-STATUS; PC,MILKY,0103-005638	SNA	1
3	JC95-01447A	2	L7163	JC61-00022A	SPRING ETC-HOOK; SF-5100,SUS304-WPB,0.26,	SA	2
4	JC95-01447A	2		JC64-00542D	KEY-POWER_NEW; ML-1660,ABS,HB	SNA	1
5	JC95-01447A	2		JC64-00543D	KEY-PRINTSCREEN_NEW; ML-1660,ABS,HB,Crema	SNA	1
6	JC98-01340C	2	F9835	6003-000282	SCREW-TAPTYPE; BH,+,-,B,M3,L8,ZPC(BLK),SW	SNA	2

Exploded Views and Parts List

No.	Parent	Lvl.	Loc.	Material Code	Description & Specification	SNA	Qty.
7	JC95-01447A	2		JC63-03142A	COVER-OPEN; ML-1670,ABS,2,BLACK	SNA	1
8	JC95-01447A	2	L9472	JC63-02629A	SHEET-STACKING; ML-1660,PET,0.188,BLACK	SNA	2
9	JC95-01447A	2	L9445	JC61-03973A	HOLDER-SHAFT; ML-1660,POM,21.8,BLACK	SA	1
10	JC95-01447A	2		JC61-03965C	STACKER-MAIN_NEW; CLP-325,ABS,112,107.77,	SNA	1

4. Cover

Exploded View

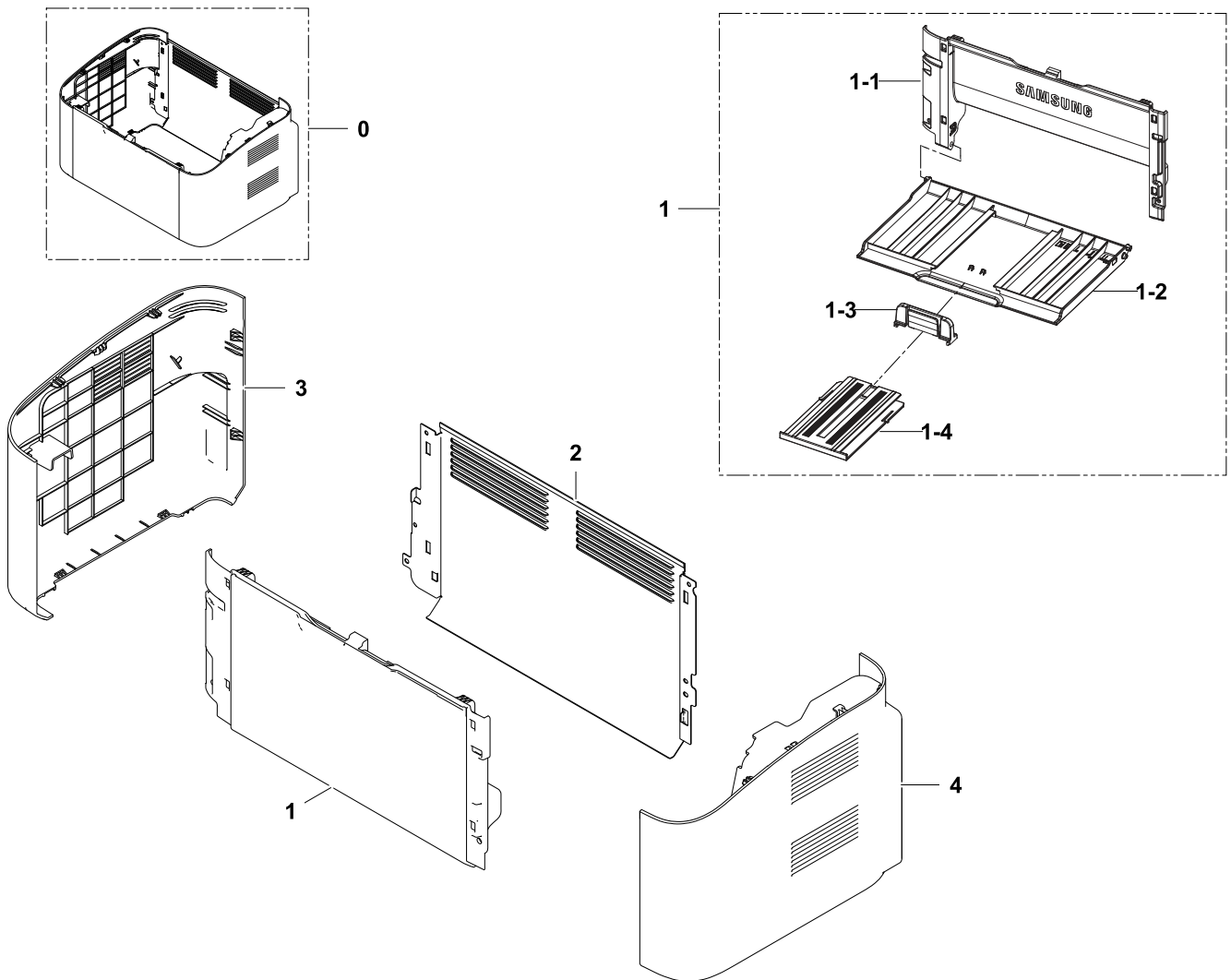

Parts List

No.	Parent	Lvl.	Loc.	Material Code	Description & Specification	SNA	Qty.
0	ML-1670/SEE	1		JC95-01448A	COVER; ML-1670,SEC,CREMA GRAY	SNA	1
1	JC95-01448A	2		JC95-01214C	COVER-FRONT; ML-1670,SEC,CREMA GRAY	SA	1
1-1	JC95-01214C	3		JC63-02619B	COVER-INNER; ML-1670,HIPS,2,CREMA GRAY,HB	SNA	1
1-2	JC95-01214C	3		JC63-02620B	COVER-CASSETTE; ML-1670,HIPS,2.3,CREMA GR	SNA	1
1-3	JC95-01214C	3		JC63-02623B	TRAY-EXTENSION L; ML-1670,HIPS,2.0,CREMA	SNA	1
1-4	JC95-01214C	3		JC63-02624B	TRAY-EXTENSION S_NEW; ML-1660,HIPS,2.0,So	SNA	1
2	JC95-01448A	2	L9437	JC61-03787A	BRACKET-REAR; ML-1660,SECC,0.6	SNA	1

Exploded Views and Parts List

No.	Parent	Lvl.	Loc.	Material Code	Description & Specification	SNA	Qty.
3	JC95-01448A	2		JC95-01212B	COVER-LEFT; ML-1670,SEC,CREMA GRAY	SA	1
4	JC95-01448A	2		JC95-01213B	COVER-RIGHT; ML-1670,SEC,CREMA GRAY	SA	1